

Speed indicator DR 1010

Revolution per minute - speed - flow

Features

- LED-Display 14.2mm red
- Display range 0 ... 99999
- 0 ... 3 decimal points or floating point programmable
- Inputs for switching contacts, pnp-initiators and Namur-initiators
- Programmable input-prescaler
- Time base min^{-1}
- Integrated transmitter-supply 24 / 8V DC
- Hold-input
- Max. 2 outputs, SPDT relay
- Protection IP65



Fieldcase
100x100x60mm (WxHxD)

General

The Speed Indicator DR1010 has been designed for field applications in process control and automation. Parameters for operation mode can be programmed. The DR1010 can be used wherever processes based per minute just as speed should be measured and displayed.

Short information

Programming	Parameters are programmed via front-side membrane keypad
Transmitter-supply	The integrated transmitter supply allows direct connection of pnp initiators, light barriers, mechanical switch contacts, proximity switches, rotary encoder (24V DC) and Namur initiators (8V DC).
Input prescaler	An input prescaler function for both inputs is programmable.
Preset outputs	Preset outputs can be programmed as continues contact or pulse contact. Switching performance is programmable as minimum or maximum function.
Hold function	Freezing the display by control voltage 24V DC or voltage free contact.

For more features like math functions- summing, difference and display conversion, etc. please choose Productivity Panelmeter **PR9648**.

Technical data

Power supply

Supply voltage	: 230V AC \pm 10%; 115V AC \pm 10%; 24V AC \pm 10% or 24V DC \pm 15%
Power consumption	: max. 3.5VA
Operating Temperature	: -20 ... +55°C Standard (extended temperature range on request)
Rated voltage	: 250V~ acc. VDE 0110 between input / output / supply voltage Degree of pollution 2, over-voltage category III
Test voltage	: 4kV-, between input / output / supply voltage
CE - conformity	: EN55022, EN60555, IEC1000-4-3/4/5/11/13

Input

pnp input	: Ri = 6.3k Ω level: < 4V low; > 8.5V high; hysteresis > 2.5V, max. 35VDC
Namur input	: Ri appr. 1k Ω (<4mA) level: < 1mA low; >2.2mA high; hysteresis > 0.5mA max. 35V
Counting frequency max.	: Input E1 = 1Hz ... 30 Hz, (switch contact) Input E2 = 1Hz ... 15kHz, (pnp-initiator or Namur)
Accuracy	: \leq 0.003%, \pm 1 Digit
Min. pulse width	: Electronic pulse 50 μ s, switch contact 5ms
Transmitter supply	: 8V DC (Namur), 24V DC (pnp), Ri appr. 150 Ω , max.50mA

Display

Indicating range	: 0 ... 99999 Digit with leading zero suppression
Additional display	: LED 2-digit red, 7mm (parameter - and output indicator)

Output

Relay	: SPDT <250V AC<250VA<2A, <300V DC<50W<2A
-------	---

Field case

Material	: PA6-GF 15/15
Weight	: max. 350g
Connection	: Clamp terminals, 2mm ² wire, 1mm ² flexible wire, AWG14
Protection	: Front IP65, terminals IP20, fingersafe acc. BGV A2 (old VBG4)

Dimensions

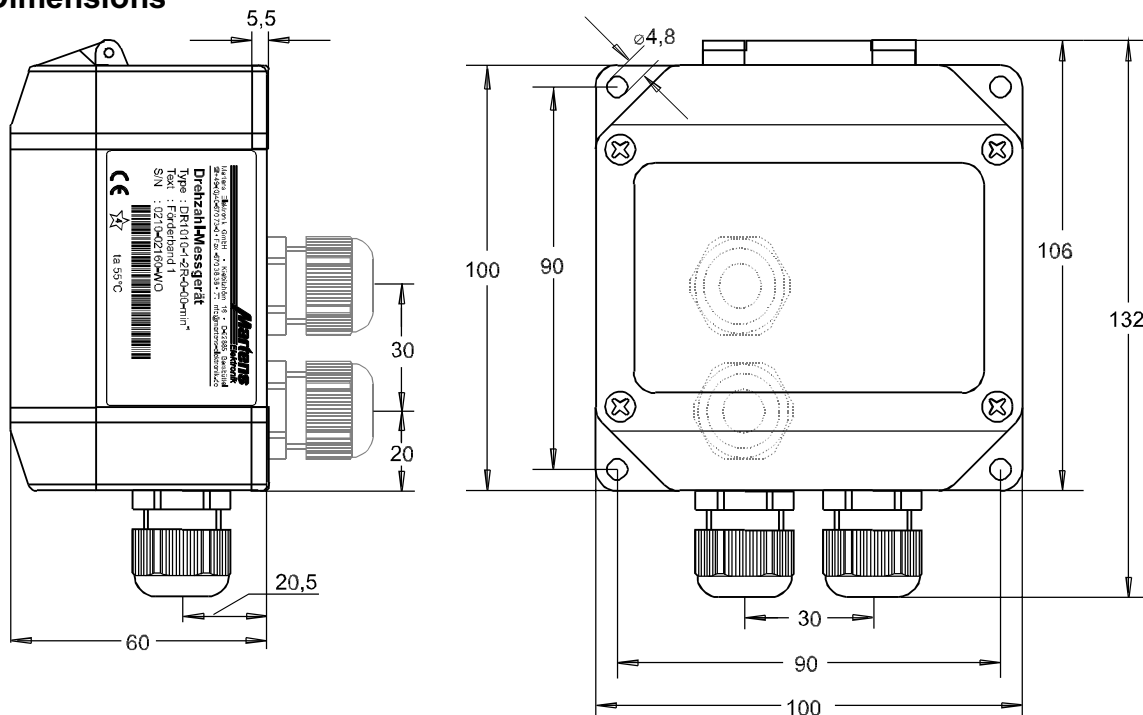

2 x Pg11 cable glands
(In the base on request)

Legend (Open lid)

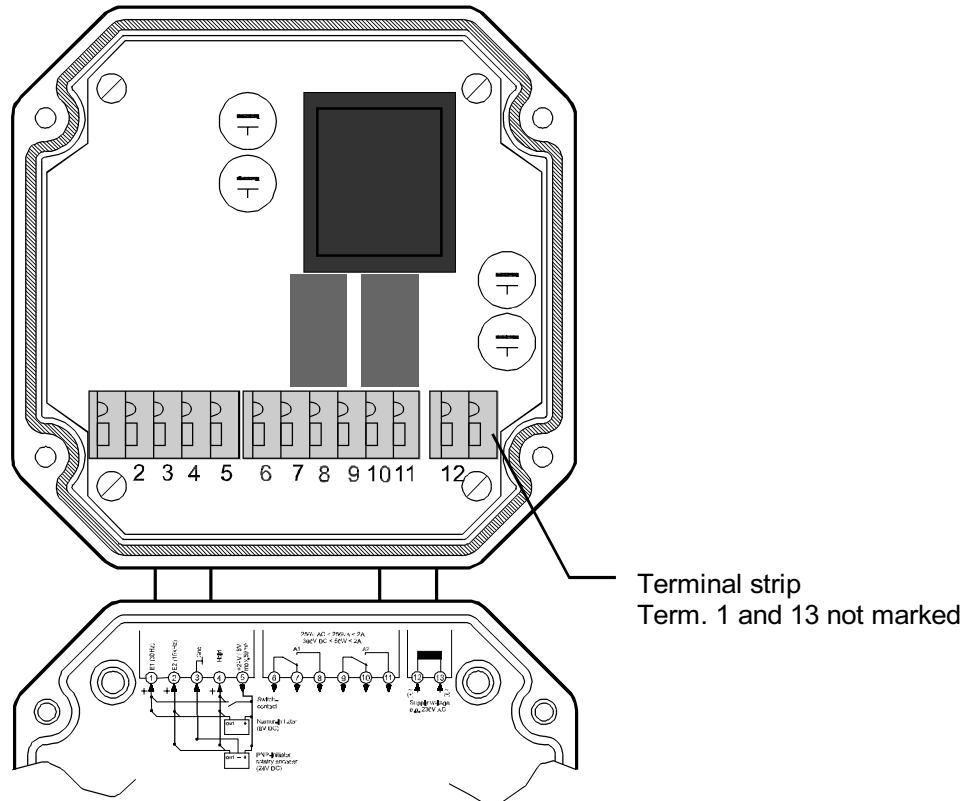

Connection diagram

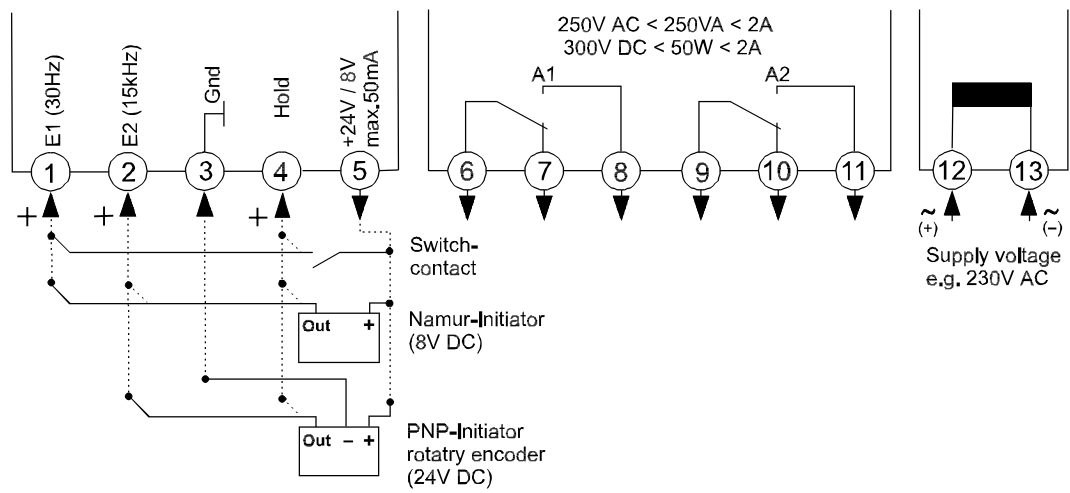

Controls- and indicators

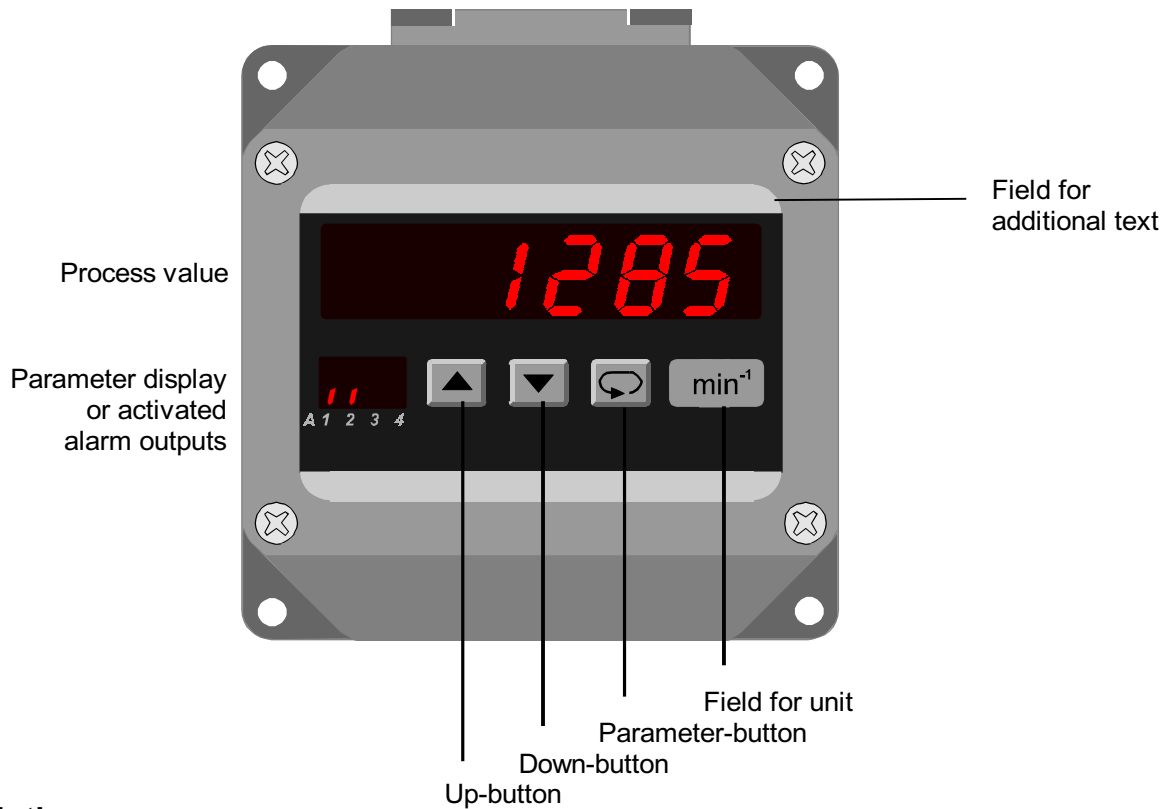

Description

Operation of the device is arranged in 2 levels. The requested parameter can be called by button. Selection within a parameter or entering data use button and . Parameters are stored zero-voltage safe in the EEPROM.

Button combinations

- + one parameter back
- + setting parameter to zero or minimum value

After turn on the supply voltage the device is working in the **Working level**.

Set points of alarm outputs can be programmed if available.

Activating the button program for more than 2 seconds the program is jumping into the **Configuration level**. Now all the parameters defining the function of the device can be programmed.

After finishing the configuration or when longer than 2 minutes no button was pushed, the program jumps back to the working level. Leaving the configuration level is possible at any time when pushing the button .

Error codes:

PE Reading this symbol in the parameter display a parameter failure has been occurred. The display flashes. When pushing one of the buttons the error code will be deleted and the device is running with factory programmed parameters. Configuration and function of the device must be checked. If error occurs again, please ship the device to factory for repair service.

Lo c Programming lock active. See configuration page 7.

o F Overflow

Start-up note:

Before the device can be used, it must be configured for the intended use.

⇒ see page 6

Notes to representation



Parameter only shown when configured













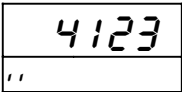
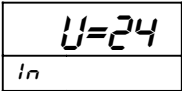



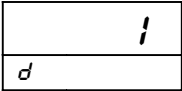

Parameter is only shown when installed in the device (see order code)

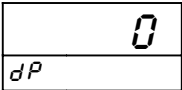
Note: All parameters can be called if they are not blocked by other programmed parameters and if they are available. Factory settings are shown in [].



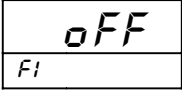













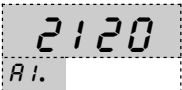



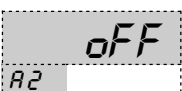



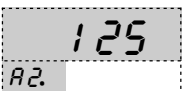



Working level

Button	Display	Description
↓		Working level Output indication (only if installed and activated).
↺		
↓		Setpoint output A1 Setting possible from 0 ... 99999 digit, with button ▲ and ▼.
↺		
↓		Setpoint output A2 Setting possible from 0 ... 99999 digit, with button ▲ and ▼.
↺		

Configuration level

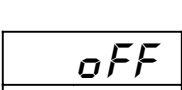
Button	Display	Description	[Factory settings]
 press 2 sec.		Working level	
↓		Transmitter supply / input level $U = 24$ = 24V DC for pnp-initiators $U = 8$ = 8V DC for Namur-initiators * with ext. 5V supply also useful for TTL-signals) $t E 5 t$ = only for factory settings Selection with buttons  and  .	[U = 24]
			
↓		Prescaler for input E1 and E2 Setting possible from 1 ... 9999 digit with buttons  and  . (Only every n th pulse is displayed)	[1]
			
↓		Decimal point position <i>Auto</i> (floating point) .000 .00 .0 0. 0.	[0.]
		Maximum 3 decimal point positions possible. In the Auto-mode the decimal point changes automatically > 30.000 digit Selection with buttons  and  .	
↓		Digital filter <i>oFF</i> <i>on</i> If the Process value > 100, the last digit set to zero. Selection with button  and  .	[oFF]
			

continue
page 7

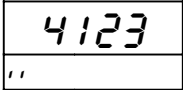
Button	Display	Description	[Factory settings]
↓ 		Switching performance preselect (alarm) output A1 <i>oFF</i> = no output <i>o n L</i> (min) = continuous contact: on-off <i>o n U</i> (max) = continuous contact: off-on Selection with buttons  and  .	[<i>oFF</i>]
			
↓ 		Setpoint output A1 Setting possible from 0 ... 999999 digit, with buttons  and  (<i>A u t o</i> - mode settings without decimals).	[0]
			
↓ 		Switching performance preselect (alarm) output A2 <i>oFF</i> = no function <i>o n L</i> (min) = continuous contact: on-off <i>o n U</i> (max) = continuous contact: off-on Selection with buttons  and  .	[<i>oFF</i>]
			
↓ 		Setpoint output A2 Setting possible from 0 ... 99999 digit with buttons  and  (<i>A u t o</i> - mode settings without decimals).	[0]
			
↓ 		Common hysteresis ; for outputs A1 A2. Setting possible from 1 ... 9999 digit with buttons  and  Decimal points only shown if 1 decimal point programmed. Parameter only displayed if at minimum 1 output is activated. (<i>A u t o</i> - mode settings without decimals).	[1]
			
↓ 		Program lockout <i>oFF</i> = no lock <i>C o n F.</i> = configuration level locked <i>A L L</i> = all parameters locked Selection with buttons  and  .	[<i>oFF</i>]
			
		Return to the working level	

Order code

DR1010 - 1. - 2. - 3. - 4. - 5. - 6.

1. Input

1 2 Impulse inputs,
integrated transmitter-supply,
Hold-input

2. Alarm output

00 not installed
2R 2 alarm outputs relay

3. Supply voltage

0	230V 50/60Hz	±10%
1	115V 50/60Hz	±10%
4	24V 50/60Hz	±10%
5	24V DC	±15%

4. Option

00 without option

6. **Unit** (appears on the unit field)

7. **Additional text** (appears on the face plate in the field for additional text
max. 3mm x 70mm HxW)

Ihr kompetenter Ansprechpartner / Your competent contact partner :

SCHRIEVER & SCHULZ & Co. GmbH Ing.- und Verkaufsbüro * seit 1958 * Eichstr. 25 B, D - 30880 Laatzen
Tel ++49 (0) 511 86 45 41 / Fax ++49 (0) 511 86 41 56 * www.schriever-schulz.de | schriever@schriever-schulz.de