

# Standard Signal Meter S 1010

Industry standard signals -  
integrated transmitter-supply

## Features

- LED-Display 14.2mm red
- Indicating range  $\pm 9999$  Digit
- Indicating range and decimal point free programmable
- Max. 2 Alarm outputs
- Analog output 0/4 ... 20mA and 0/2 ... 10V DC
- Field case with snap lid
- Protection IP65



Field case 100x100x60mm  
with 2 PG11 cable glands

## General

The Standard-Signal-Meter S1010 has been designed for measuring industry standard signals 0/4 ... 20mA or 0 ... 10V DC. The device offers an integrated transmitter supply for direct connection of 2- and 3-wire transmitters for e.g. pressure or temperature. Indicating range and decimal point are free programmable in the range  $\pm 9999$  digit.

## Short information

Programming	Parameters are programmed via front-side membrane keypad.
Alarm outputs	Switching performance for the alarm outputs is programmable as minimum or maximum function.
Digital filter	With activated digital filter last 16 measured values will be averaged continuously and the result shown in the display.
Analog output	Proportional to the input signal an analog output signal 0 ... 20mA / 0 ... 10V DC or 4 ... 20mA / 2 ... 10V DC can be generated. Output changed automatically from current signal to voltage signal depending on burden.

## Technical data

### Supply power

Supply voltage	: 230V AC $\pm 10\%$ ; 115V AC $\pm 10\%$ , 24V AC $\pm 10\%$ or 24 V DC $\pm 15\%$
Power consumption	: max. 3.5VA, with analog output 5VA
Operating temperature	: -20 ... +55°C Standard (extended temperature range on request)
Rated voltage	: 250V~ acc. VDE 0110 between input / output / supply voltage over-voltage categoric III

Test voltage : 4kV-, between input / output / supply voltage

CE - conformity : EN55022, EN60555, IEC1000-3/4/5/11/13

### Input

Current input	: 0/4 ... 20mA	Ri = 10 $\Omega$
Voltage input	: 0 ... 10V	Ri = >100k $\Omega$
Accuracy	: < 0.1% $\pm 2$ Digit	
Temperature coefficient	: 0.004% / K	
Transmitter-supply	: U <sub>0</sub> appr. 24V, Ri appr. 150 $\Omega$ , max.50mA (25mA with relay and analog output)	

**Display** : LED red, 14.2mm

Display range :  $\pm 9999$

Parameter display : LED 2-digit red, 7mm (parameter - and output indicator)

### Output

Relay : SPDT, <250V AC<250VA<2A, <300V DC<50W<2A

Analog output : 0/4 ... 20mA burden  $\leq 500\Omega$ ; 0/2 ... 10V burden  $> 500\Omega$ , not isolated to the input  
automatic output changing (burden dependent)

Accuracy : 0.1%; TK 0.01% / K

**Field case** : Case polyamide, with fibre-glass PA6-GF 15/15, Keypad polyester

Weight : max. 450g

Electrical connection : Clamp terminals, 2mm<sup>2</sup> single wire, 1mm<sup>2</sup> flexible wire, AWG14

Protection : IP65, terminals IP20, fingersafe acc. German BGV A2 (old VBG4)

## Dimensions

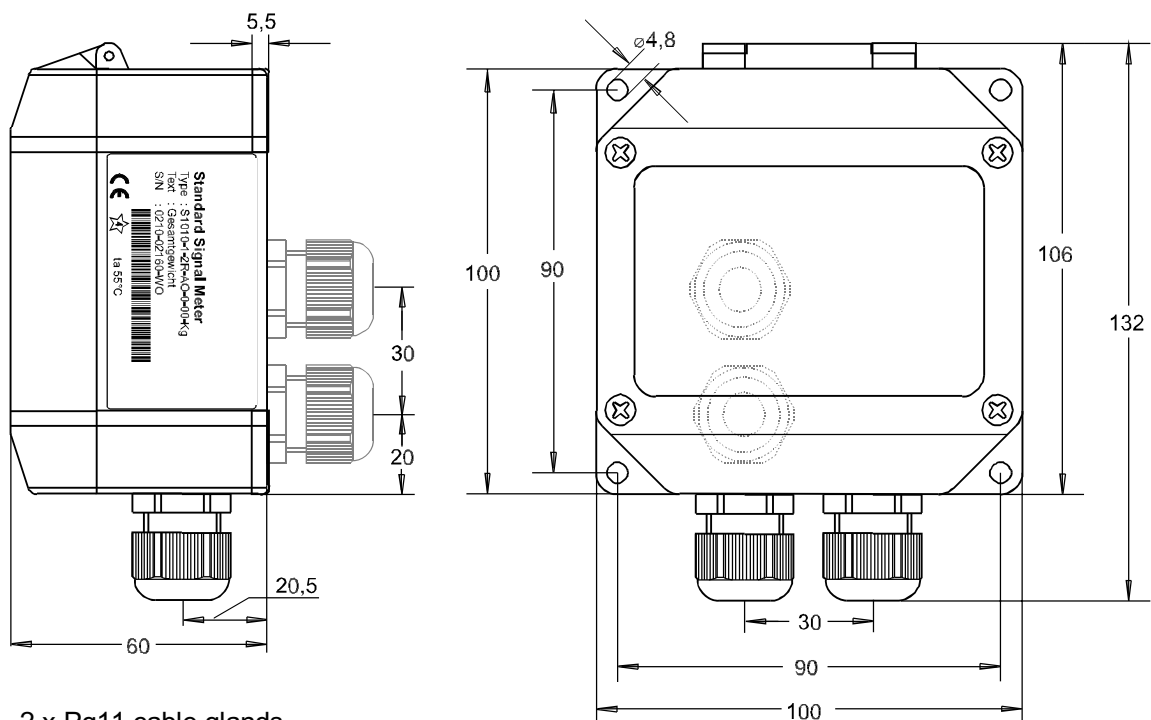

2 x Pg11 cable glands  
(In the base on request)

## Legend (opened lid)

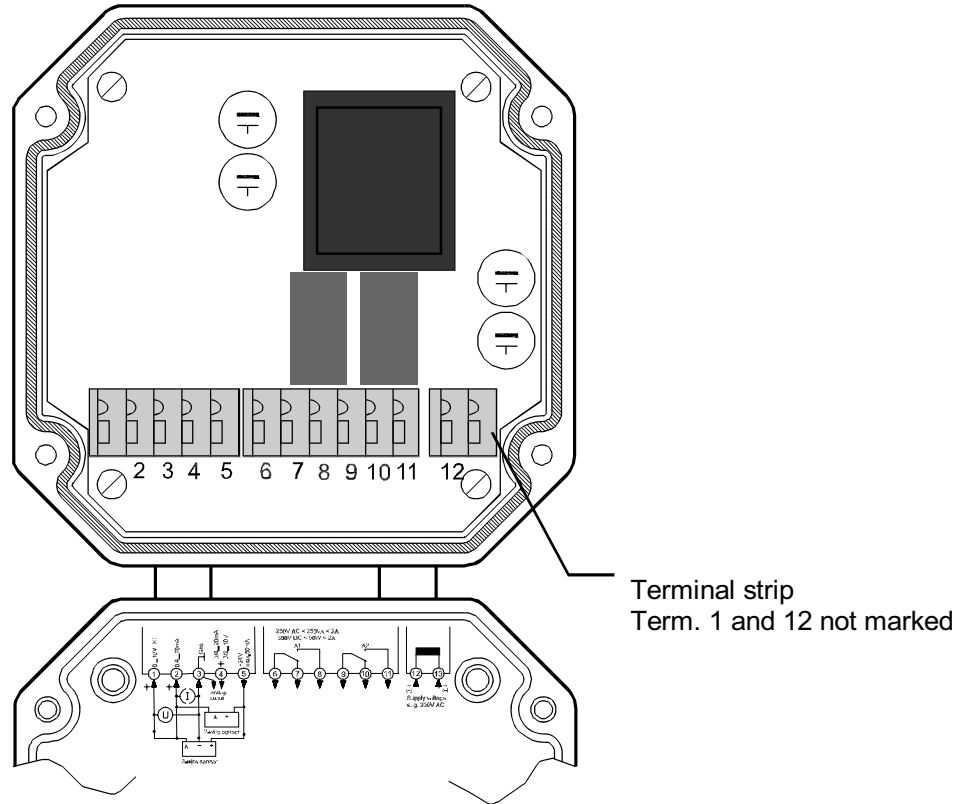

## Connection diagram

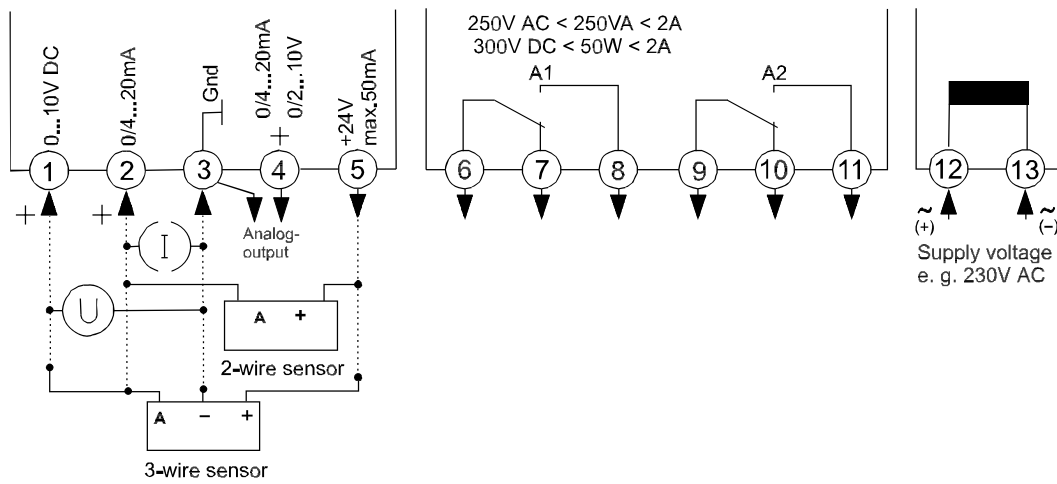

## Controls and indicators

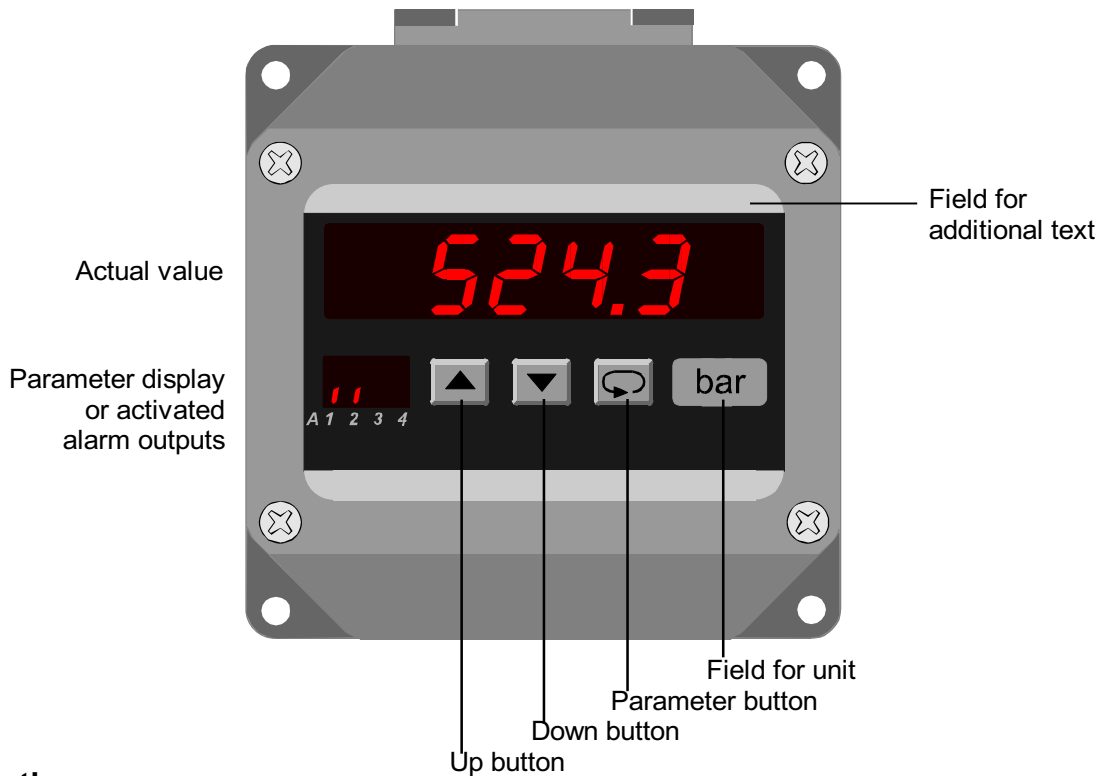

### Description

Operating of the device is arranged in 2 levels. The requested parameter can be called by button. Selection within a parameter or entering data, use buttons and . Parameters are stored zero-voltage safe in the EEPROM.

After switching on the supply voltage, the device initializes itself. The display shows the message *init*. After the initializing procedure the device is working in the **Working level**. Set points of the alarm outputs can be preselected if available.

Activating the button for more than 2 seconds, the program is jumping into the **Configuration level**. Now all the parameters defining the function of the device can be programmed.

After finishing the configuration or when longer than 2 minutes no button was pushed, the program jumps back to the working level. Leaving the configuration level is possible at any time when pushing the button for 2 seconds.

### Error codes:

**Display flashes** If the input signal is more than 3% outside of the programmed measurement range the A/D- converter is over driven and the display flashes with appr. 1Hz

**Error!** EEPROM test. Reading this message, a program error has been occurred. When pushing the button a copy of the EEPROM will be reloaded and the device will work with the factory settings. If this copy does not work, please ship the device to factory for repair service.

**Loc** Program lockout. See configuration page 7.

### Start-up note:

Before the device can be used, it must be configured for the intended use

⇒ see page 6











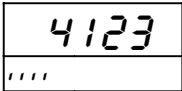

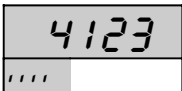



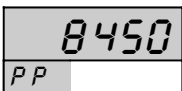



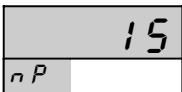

## Notes to representation

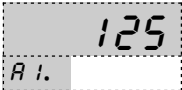
 Parameter is only displayed when configured



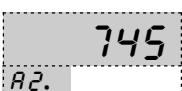







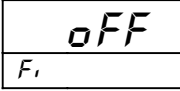



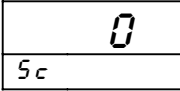



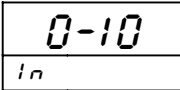



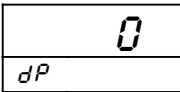



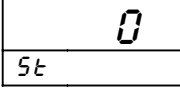

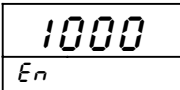

 Parameter is only displayed when feature is included (see order code)

Please note: All parameters can be called if they are not blocked by other programmed parameters and if they are available. Factory settings are shown in [ ] .

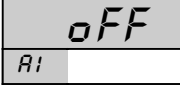
## Working level

Button	Display	Description
		Actual value. Alarm output indication (only if installed and activated).
		Display brightness (permanent changing possible ) Setting possible in 9 steps with buttons  and  .
		Display maximum reading. Reset with buttons  or  , or at every power off.
		Display minimum reading. Reset with buttons  or  , or at every power off.
		Setpoint output A1. Setting possible from $St \dots En$ with buttons  and  . $St$ (start value) ... $En$ (end value)
		Setpoint output A2. Setting possible from $St \dots En$ with buttons  and  . $St$ (start value) ... $En$ (end value).
		

## Configuration level

Button	Display	Description	[ Factory settings ]
 press 2 seconds		Digital filter. <i>oFF, on</i> Averaging of the last 16 measured values continuously. Selection with buttons  and  .	[ <i>oFF</i> ],
		Indicating correction. Setting possible from <i>-99 ... 99</i> digit with buttons  and  .	[ <i>0</i> ]
		Input signal. <i>0-10; 0-20; 4-20</i> Selection with buttons  and  .	[ <i>0-10</i> ]
		Decimal point position. <i>0. 0 .00 .000</i> Selection with buttons  and  .	[ <i>0.</i> ]
		Start value for indicating range and analog output. Setting possible from <i>-9999 ... 9999</i> digit with buttons  and  . In case of modification new configuration of the alarm outputs is necessary.	[ <i>0</i> ]
		End value for indicating range and analog output. Setting possible from <i>-9999 ... 9999</i> digit with buttons  and  . In case of modification new configuration of the alarm outputs is necessary. If $5t > En$ , output works with a decreasing characteristic.	[ <i>1000</i> ]
		Switching performance output A1. Function <i>oFF</i> ; <i>on L</i> (min); or <i>on U</i> (max). If activated the start value will be loaded for set point Selection with buttons  and  .	[ <i>oFF</i> ]
		Set point output A1. Setting possible from $5t$ (start value) ... $En$ (end value) with buttons  and  .	[ <i>0</i> ]

continue  
page 7

Button	Display	Description	[ Factory setting ]
↓		Hysteresis A1. Setting possible from 1 ... 9999 digit with buttons ▲ and ▼ .	[ 10 ]
↺		<b>Note:</b> Switching performance and setpoint of the alarm outputs A1 to A2 are identical.	
↓		Analog output. 0 - 20 mA (0 - 10 V DC) or 4 - 20 mA (2 - 10 V DC). Changing from current to voltage output is load-dependent (≤ 500Ω = current output, > 500Ω = voltage output). Selection with buttons ▲ and ▼ .	[ 0 - 20 ]
↺			
↓		Analog output Start value (Option 08) Setting possible from 5t ... En of the display range with buttons ▲ and ▼ .	[ 0 ]
↺			
↓		Analog output End value (Option 08) Setting possible from 5t ... En of the display range with buttons ▲ and ▼ .	[ 1000 ]
↺		<b>Note:</b> If the display range would be changed afterwards, the range of the analog output get the same values. Start- and end value of the analog output can be set anywhere in the display range. If RE < R5 the output works with a decreasing characteristic.	
↓		Code for factory settings.	
↺			
↓		Program lockout. oFF = no lock LcOnF. = configuration level locked ALL = all parameters locked Selection with buttons ▲ and ▼ .	[ oFF ]
↺			
		Return to the working level.	

## Order code

S1010 -  1. -  2. -  3. -  4. -  5. -  6. -  7.

### 1. Input

1 Input standard signals  
0/4 ... 20mA, 0 ... 10V DC,  
integrated transmitter-supply 24V DC max. 50mA

### 2. Alarm output

00 not installed  
2R 2 alarm outputs relay

### 3. Analog output

00 not installed  
AO Analog output 0/4 ... 20mA and 0/2 ... 10V DC, not isolated

### 4. Supply voltage

0 230V 50/60Hz ±10%  
1 115V 50/60Hz ±10%  
4 24V 50/60Hz ±10%  
5 24V DC ±15%

### 5. Option

05 without option  
01 Min-and Max-value hold  
07 Display brightness programmable  
08 Analog output free programmable

### 6. Unit (appears in the unit field)

### 7. Additional text (will be placed in the field for additional text max. 3mm x 70mm HxW)

---

Ihr kompetenter Ansprechpartner / Your competent contact partner : \* seit 1958 \*

**SCHRIEVER & SCHULZ** & Co. GmbH Ing.- und Verkaufsbüro \* Eichstr. 25 B, D - 30880 Laatzen  
Tel ++49 (0) 511 86 45 41 / Fax ++49 (0) 511 86 41 56 \* [www.schriever-schulz.de](http://www.schriever-schulz.de) | [info@schriever-schulz.de](mailto:info@schriever-schulz.de)