

Temperature-Panelmeter T 9648

RTD Pt100 - Pt1000 - Thermocouple

Features

- LED-Display 14.2mm red
- Measuring input:
Pt100 -100.0 ... 600.0°C*
Pt1000, -50.0 ... 200.0°C*
Fe-CuNi(J), 0 ... 800.0°C*
NiCr-Ni(K), 0 ... 1200°C
Pt10Rh-Pt(S), 0 ... 1600°C
*switch off decimal point possible
- 2nd measuring input (only Pt100; Pt1000) for difference temperature, average value etc..
- Max. 4 alarm outputs, SPDT relay or transistor
- Isolated analog output.
0/4 ... 20mA and 0/2 ... 10V DC
- Serial interface CANopen bus
- Front protection IP65



DIN 96x48mm

General

The Temperature-Panelmeter T9648 is suitable for measurement of temperatures in connection with RTD sensors Pt100, Pt1000 and thermocouples Fe-CuNi (J), NiCr Ni (K), Pt10Rh-Pt (S). Devices for other temperature sensors are available on request. The measuring input is isolated. The measuring range can be limited in the configuration level. It is identical with the range of the analog output.

Short information

Programming	Programming is made via front-side membrane keypad.
Alarm outputs	Switching performance for the alarm outputs is programmable as minimum or maximum function.
Digital filter	With activated digital filter last 16 measured values will be averaged continuously and the result shown in the display.
Analog output	Proportional to the input signal an isolated analog output signal 0 ... 20mA / 0 ... 10V DC or 4 ... 20mA / 2 ... 10V DC can be generated. Output changed automatically from current signal to voltage signal depending on burden.
2 nd measuring input*	The device can be offered with a 2 nd measuring input Pt100 or Pt1000 at terminal strip B. It is not possible to mix Pt100 or Pt1000 signals. In this way difference temperatures, average value, larger or smaller value can be displayed. Please ask for further information.

***Note:** no galvanic isolation between measuring input 1 (terminal strip A) and 2nd measuring input.

Technical data

Power supply

Supply voltage	: 230V AC $\pm 10\%$; 115V AC $\pm 10\%$, 24V AC $\pm 10\%$ or 24V DC $\pm 15\%$
Power consumption	: max. 3.5VA, with analog output 5VA, with CAN-Bus 6VA
Operating temperature	: -10 ... +55°C
Rated voltage	: 250V~ acc. to VDE 0110 between input / output / supply voltage Degree of pollution 2, over voltage category III
Test voltage	: 4kV-, between input / output / supply voltage
CE - Conformity	: EN55022, EN60555, IEC1000-4-3/4/5/11/13

Input

Pt100 / Pt1000	: -100 ... 600°C / -50 ... 200°C
-Accuracy	: Pt100 and Pt1000 < 0.1% ± 2 Digit, max. 100 Ohm line resistant
Thermocouples	: Fe-CuNi (J) 0 ... 800°C, NiCr-Ni (K) 0 ... 1200°C and Pt10Rh-Pt (S) 0 ... 1600°C reference junction compensation inserted.
-Accuracy	: < 0.1% ± 2 digit with compensating cable
Temperature coefficient	: 0.004%/K

Display

Indicating range	: Input-dependently, with leading zero suppression.
Parameter display	: LED 2-digit red, 7mm (parameter - und output indicator)

Output

Relays	: SPDT <250V AC<250VA<2A, <300V DC<50W<2A
Transistor	: max. 35V AC/DC / 100mA, short circuit protection
Analog output	: 0/4 ... 20mA burden $\leq 500\Omega$; 0/2 ... 10V burden $> 500\Omega$, isolated automatic output changing (load dependent)
-Accuracy	: 0.1%; TK 0.01% / K
CAN-Bus	: CANopen, standard

Panel case

Dimensions	: DIN 96x48mm, material PA6-GF; UL94V-0
Weight	: max. 390g
Connection	: Clamp terminals, 2mm ² single wire, 1mm ² flexible wire, AWG 14
Protection	: Front IP65, terminals IP20, fingersafe acc. <German BGV A2 (old VBG4)

Dimensions

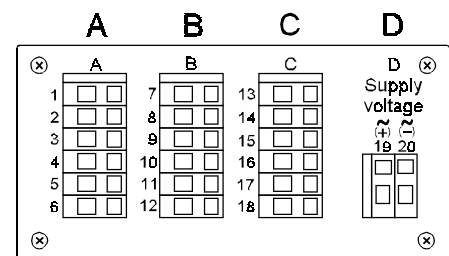
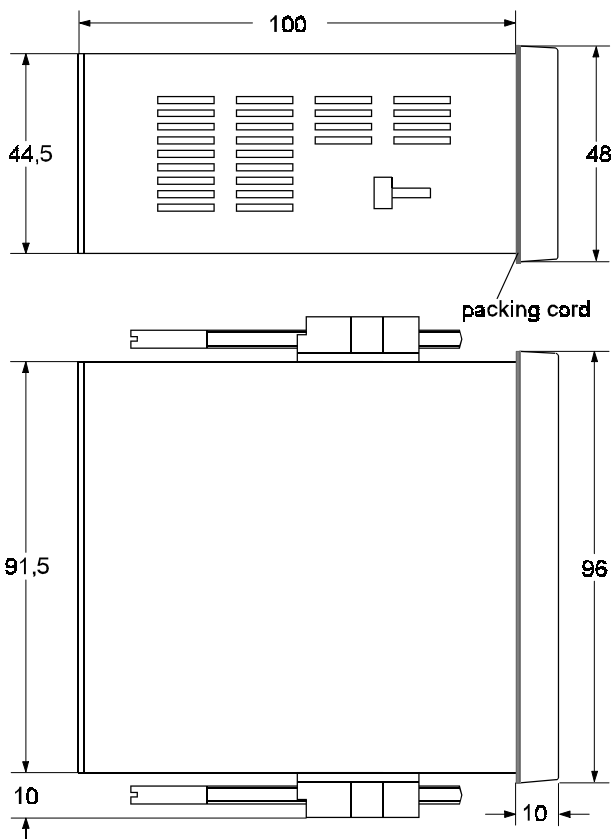

Position terminal strips

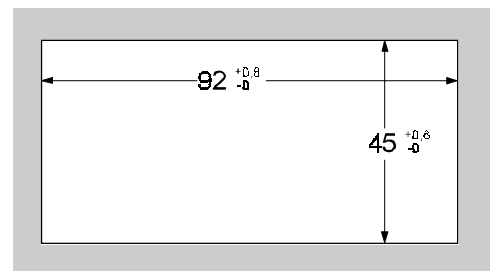

Panel cut-out
acc. to DIN 43700-96x48mm

Connection diagram

Terminal strip A (varies with versions)
Pt100 or Pt1000 input

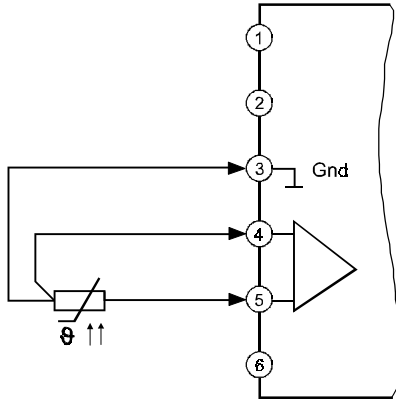

Thermocouple input

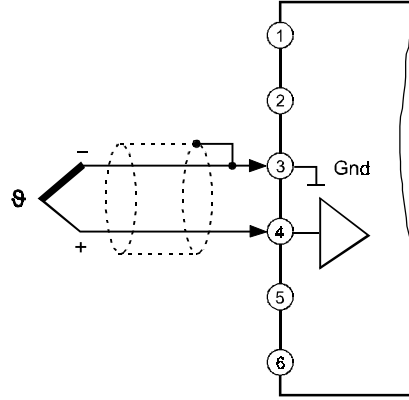

Terminal strip B (varies with versions)
2 Alarm outputs

Relays

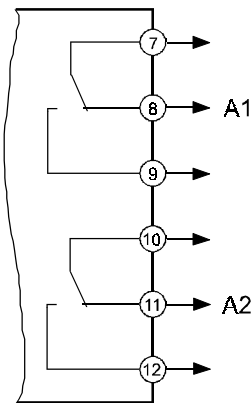

Transistor

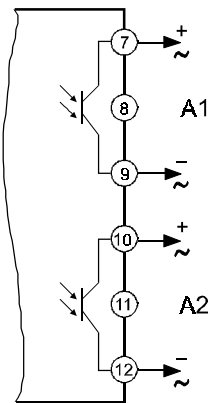

2nd input
only Pt100 or Pt1000

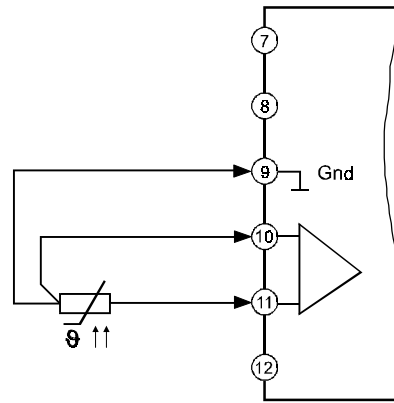

Terminal strip C (varies with versions)
2 Alarm outputs

Relays

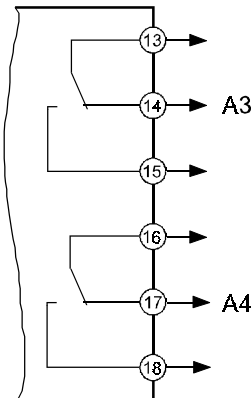

Transistor

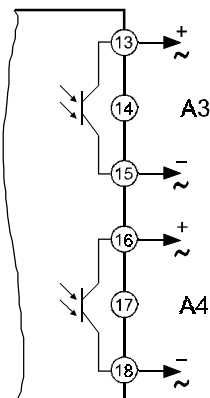

Analog output
AO

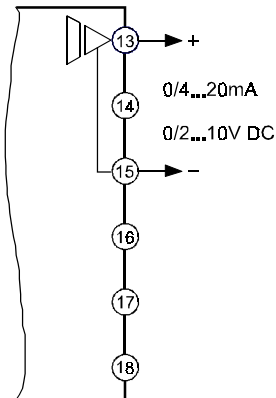

Serial interface
CAN-Bus

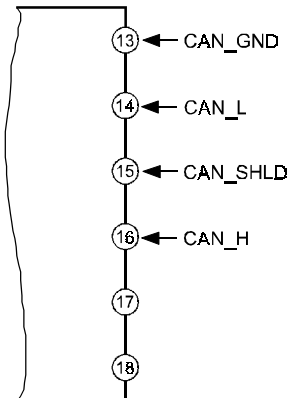

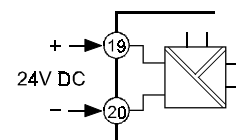
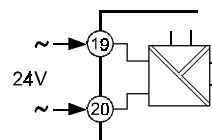
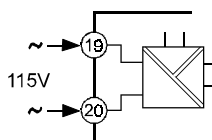
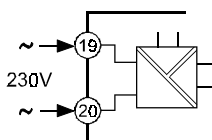

Terminal strip D Supply voltage (varies with versions)

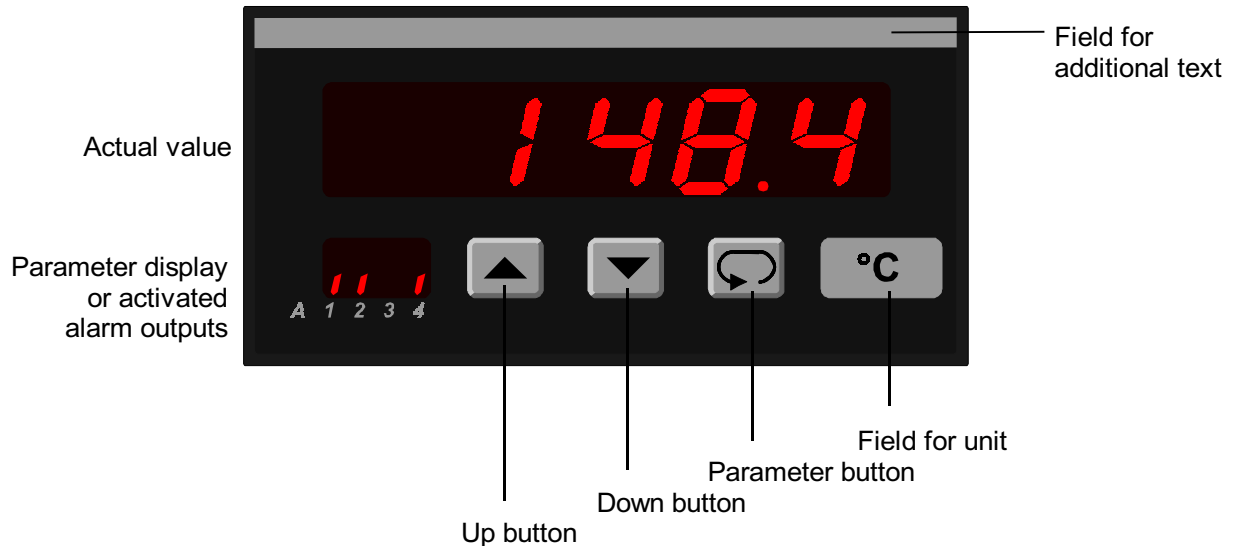

Controls- and Indicators





Description

Operating of the device is arranged in 2 levels. The requested parameter can be called by  button. Selection within a parameter or entering data, use buttons  and . Parameters are stored zero-voltage safe in the EEPROM.

After switching on of the supply voltage, the device initializes of itself. The display shows the message *init*.

After the initializing procedure the device is working in the **Working level**. Setpoints of the alarm outputs can be preselected if available.

Activating the  button for more than 2 seconds, the program is jumping into the **Configuration level**. Now all the parameters defining the function of the panelmeter can be programmed. This may be the switching performance of the alarm outputs and the analog output.

After finishing the configuration or when longer than 2 minutes no button was pushed, the program jumps back to the working level. Leaving the configuration level is possible at any time when pushing the button  for 2 seconds.

Error codes:

Display flashes The input signal is more than 3% outside of the programmed measurement range the A/D-converter is over driven, the display flashes with appr. 1Hz.

Error! EEPROM test. Reading this message, a program error has been occurred. When pushing the button  a copy of the EEPROM will be reloaded and the device will work with factory settings. If this copy doesn't work, please ship the panelmeter to factory for repair service.

Loc Programming locked. See configuration page 7.

Start-up note:

Before the device can be used, it must be configured for the intended use

⇒ see page 6











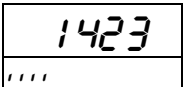



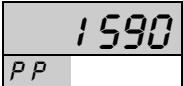



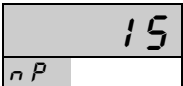







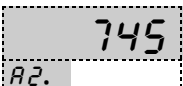

Note of representation

 Parameter is only displayed when configured



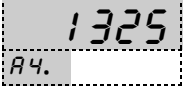







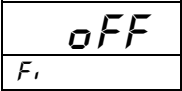



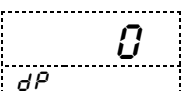

 Parameter is only displayed when feature is included (see order code)

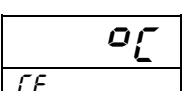
Note: All parameters can be called if they are not blocked by other programmed parameters and if they are available. Factory settings are shown in [].

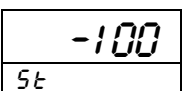
Working level

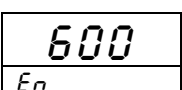
Button	Display	Description
		Actual value
		Output indication. (only if installed and activated).
		Display peak reading. Reset with buttons  or  , or at every power off.
		Display valley reading. Reset with buttons  or  , or at every power off.
		Setpoint output A1. Setting possible from $5t \dots E_n$ with buttons  and  . $5t$ (start value) ... E_n (end value).
		Setpoint output A2. Setting possible from $5t \dots E_n$ with buttons  and  . $5t$ (start value) ... E_n (end value).
		Setpoint output A3. Setting possible from $5t \dots E_n$ with buttons  and  . $5t$ (start value) ... E_n (end value).
		Setpoint output A4. Setting possible from $5t \dots E_n$ with buttons  and  . $5t$ (start value) ... E_n (end value).
		

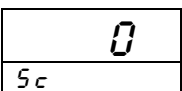
Configuration Level

Button	Display	Description	[Factory settings]
 press 2s		Digital filter . OFF , ON Averaging of the last 16 measured values continuously. Selection with buttons ▲ and ▼ .	[OFF]
 		Input signal selection (only thermocouples input). FE.CuNi, NiCr.Ni, PtRh.Pt Selection with buttons ▲ and ▼ . In case of modification new configuration of the alarm outputs is necessary.	[FE.CuNi]
 		Decimal point position (not NiCr.Ni and PtRh.Pt). .0 0. Selection with buttons ▲ and ▼ .	[0]
 		Unit of the temperature. °C °F Selection with buttons ▲ and ▼ .	[°C]
 		Start value for indicating range and analog output Setting possible from min. ... ϵ_n with buttons ▲ and ▼ . min: Pt100 = -100°C; Pt1000 = -50°C; Fe-CuNi, NiCr-Ni, Pt10Rh-Pt = 0°C In case of modification new configuration of the alarm outputs is necessary.	[-100]
 		End value for indicating range and analog output Setting possible from ϵ_t ... max. with buttons ▲ and ▼ . max: Pt100 = 600°C; Pt1000 = 200°C; Fe-CuNi = 800°C; NiCr-Ni = 1200°C; Pt10Rh-Pt = 1600°C In case of modification new configuration of the alarm outputs is necessary.	[600]
 		Indicating correction Setting possible from -99 ... 99 digit with buttons ▲ and ▼ .	[0]
			

continue
page 7

Button	Display	Description	[Factory settings]
↓		Switching performance output A1. Function <i>oFF</i> ; <i>on L</i> (min); or <i>on J</i> (max) In case of modification set point is set to the start value. Selection with buttons ▲ and ▼.	[<i>oFF</i>]
↺	↓		
↓		Setpoint output A1. Setting possible from $5L$ (initial value) ... E_n (final value) with buttons ▲ and ▼.	[0]
↺	↓		
↓		Hysteresis A1. Setting possible from 1 ... 9999 digit with buttons ▲ and ▼.	[10]
↺	↓		
↓		Analog output. $0 - 20$ mA (0 - 10 V DC) or $4 - 20$ mA (2 - 10 V DC). Changing from current to voltage output is load dependent. ($\leq 500\Omega$ = current output, $> 500\Omega$ = voltage output). Selection with buttons ▲ and ▼.	[0 - 20]
↺	↓		
↓		Code for factory settings.	
↺	↓		
↓		Program lockout. <i>oFF</i> = no lock <i>Conf.</i> = configuration level locked <i>ALL</i> = all parameter locked Selection with buttons ▲ and ▼.	[<i>oFF</i>]
↺	↓		
		Return to the working level.	

Configuration of CAN-Bus: Please ask for separate instruction manual.

Order code

T9648 - 1. - 2. - 3. - 4. - 5. - 6. - 7.

1. Terminal strip A

1	Input	Pt100	-100.0 ... 600.0°C
3	Input	Pt1000	-50.0 ... 200.0°C
5	Input	Thermocouple:	
		Fe-CuNi (J)	0 ... 800.0°C
		NiCr-Ni (K)	0 ... 1200°C
		Pt10Rh-Pt (S)	0 ... 1600°C

2. Terminal strip B

00	not installed		
2R	2 alarm outputs	relay	
2T	2 alarm outputs	transistor	
T1*	2 nd input	Pt100	-100.0 ... 600.0°C
T3*	2 nd input	Pt1000	-50.0 ... 200.0°C

3. Terminal strip C

00	not installed		
2R	2 alarm outputs	relay	
2T	2 alarm outputs	transistor	
AO	Analog output	0/4 ... 20mA and 0/2 ... 10V DC, isolated	
CA	CANopen standard		

4. Terminal strip D supply voltage

0	230V 50/60Hz	±10%
1	115V 50/60Hz	±10%
4	24V 50/60Hz	±10%
5	24V DC	±15%

5. Option

00	without option
01	min- and max-peak hold
02	different,- average value, higher value, smaller value

6. Unit (appears on the unit field)

7. Additional text (appears on face plate in the field for additional text, max. 3mm x 90mm HxW)

* in connection with terminal strip A, only Pt100 or Pt1000 are available (Pt100 and Pt1000 cannot be mixed).